



OVERVIEW

The ValveWorks USA M series consists of a lineup of gate valves with reliable, proven designs that are engineered and manufactured to meet the requirements of 6A. This series of gate valves offers the user several options depending on the specific application including achieving a positive seal at wellbore/flowline pressures ranging from zero to 5,000 PSI.

M series gate valves are full-bore valves. This allows for downhole tools to be passed through the wellhead and reduces turbulent flow. M series valves are similar to each other in design with only slight variations across the lineup, offering a high percentage of parts interchangeability, giving you an efficiency-driven advantage in the management and maintenance of your gate valve fleet and providing optimal lifecycle management integrity.

This brochure provides an in-depth look at the details of this series of gate valves and explains the features, benefits, characteristics, dimensional & technical data and other valuable information needed to determine which valve suits your specific application.

TABLE 1 - PRODUCT FEATURES

	MODEL MDS	MODEL MSG	MODEL MRC DS	MODEL MRC SG
FLOW DIRECTION	UNIDIRECTIONAL ^a	BIDIRECTIONAL	UNIDIRECTIONAL ^a	BIDIRECTIONAL
AVAILABLE BORE SIZES^b & RATED WORKING PRESSURES (psi)	2 1/16" 2K,3K,5K 2 9/16" 2K,3K,5K 3 1/8" 2K,3K,5K 4 1/16" 2K,3K,5K 5 1/8" 2K,3K,5K	2 1/16" 2K,3K,5K 2 9/16" 2K,3K,5K 3 1/8" 2K,3K,5K 4 1/16" 2K,3K,5K 5 1/8" 2K,3K,5K	2 1/16" 2K,3K,5K 2 9/16" 2K,3K,5K 3 1/8" 2K,3K,5K 4 1/16" 2K,3K,5K 5 1/8" 2K,3K,5K	2 1/16" 2K,3K,5K 2 9/16" 2K,3K,5K 3 1/8" 2K,3K,5K 4 1/16" 2K,3K,5K 5 1/8" 2K,3K,5K
AVAILABLE PSL^c	1,2	1,2	1,2,3,3G	1,2,3,3G
MATERIAL CLASSES	AA,BB,CC,DD,EE,FF	AA,BB,CC,DD,EE,FF	AA,BB,CC,DD,EE,FF,HH	AA,BB,CC,DD,EE,FF,HH
VALVE BODY	CAST	CAST	FORGED	FORGED
GATE TYPE	EXPANDING ^d	SLAB	EXPANDING ^d	SLAB
SEALING ACTION	MECHANICAL	PRESSURE-ENERGIZED	MECHANICAL	PRESSURE-ENERGIZED
OPERATION TYPE	MANUAL ^e	MANUAL ^e	MANUAL ^e	MANUAL ^e
BORE TYPE	FULL-BORE	FULL-BORE	FULL-BORE	FULL-BORE
GATE / SEAT SEAL	METAL TO METAL	METAL TO METAL	METAL TO METAL	METAL TO METAL
STEM TYPE	NON-RISING	NON-RISING	NON-RISING	NON-RISING
STEM PACKING TYPE	CHEVRON-V	CHEVRON-V	CHEVRON-V	CHEVRON-V
REPACKING	YES ^f	YES ^f	YES ^f	YES ^f
THRUST BEARINGS	2 ^g	2 ^g	2 ^g	2 ^g
BODY LUBRICATION FITTINGS	2	2	2	2
BODY / BONNET CONNECTION	BOLTED	BOLTED	BOLTED	BOLTED
END CONNECTIONS	FLANGED (RTJ) OR THREADED	FLANGED (RTJ) OR THREADED	FLANGED (RTJ) OR THREADED	FLANGED (RTJ) OR THREADED
TEMPERATURE RANGE	-75°F (-60°C) THRU 250°F (121°C)	-75°F (-60°C) THRU 250°F (121°C)	-75°F (-60°C) THRU 250°F (121°C)	-75°F (-60°C) THRU 250°F (121°C)

a) Equipped with a non-sealing seat on the upstream side. See engineering note titled "Model MDS & Model MRC DS" for details.

b) 2 1/16" x 1 13/16", 3 1/8" x 3 3/16", 4 1/16" x 4 1/8", and 4 1/16" x 4 1/4" available upon request.

c) Product Specification Level

d) See engineering note titled "Expanding Gate Assembly Operation Explained" for details.

e) Also referred to as "HANDWHEEL OPERATED"

f) Stuffing box can be repacked via injectable packing while the valve is in service up to the rated working pressure.

g) Valve bonnet equipped with grease port(s) and fitting(s) for bearing lubrication.



ENGINEERING NOTES

Expanding Gate Assembly Operation Explained – The expanding gate assembly consists of two main components: the gate (major) and the segment (minor). These components are assembled together using precision machined pins and high-quality precision formed and treated Nickel-Chromium alloy springs. When the valve is manually operated, the gate and segment act one against the other by means of a dual expanding wedge when the valve is either fully-opened or fully-closed. This expansion effect of the gate assembly against the valve seats through parallel faces of the gate assembly provides a strong and positive seal against pulsations and vibrations created by flow conditions.

Model MDS & Model MRC DS –These models are unidirectional gate valves equipped with an expanding gate assembly and a sealing seat in the downstream seat pocket. The upstream seat pocket is equipped with a non-sealing seat assembly. This allows pressure to bypass the upstream seat, equalize throughout the valve body, and only seal against the downstream seat assembly as the original Model M was intended. All model MDS valves are marked with a flow direction arrow for accurate installation.

NOTE: When bidirectional operation is required, a slab gate valve is necessary. M Series expanding gate valves (Model MDS and Model MRC DS) are not designed for bidirectional operation.

Pressure Testing – M series gate valves are not intended to be tested through the body lubrication fittings. These fittings are designed for lubrication purposes only. Shell tests and gate/seat tests shall be conducted from the end/outlet connection by qualified personnel.

TABLE 2 - TEMPERATURE RATINGS

TEMPERATURE CLASSIFICATION	OPERATING RANGE
K	-75°F (-60°C) TO 180°F (82°C)
L	-50°F (-46°C) TO 180°F (82°C)
N	-50°F (-46°C) TO 140°F (60°C)
P	-20°F (-29°C) TO 180°F (82°C)
S	0°F (-18°C) TO 140°F (60°C)
T	0°F (-18°C) TO 180°F (82°C)
U	0°F (-18°C) TO 250°F (121°C)
V	35°F (2°C) TO 250°F (121°C)

TABLE 3 - MATERIAL REQUIREMENTS

MATERIAL CLASS		MINIMUM MATERIAL REQUIREMENTS	
		BODY, BONNET, END & OUTLET CONNECTIONS	PRESSURE-CONTROLLING PARTS & STEMS
AA	GENERAL SERVICE	CARBON OR LOW-ALLOY STEEL	CARBON OR LOW-ALLOY STEEL
BB	GENERAL SERVICE	CARBON OR LOW-ALLOY STEEL	STAINLESS STEEL
CC	GENERAL SERVICE	STAINLESS STEEL	STAINLESS STEEL
DD	SOUR SERVICE ^a	CARBON OR LOW-ALLOY STEEL ^b	CARBON OR LOW-ALLOY STEEL ^b
EE	SOUR SERVICE ^a	CARBON OR LOW-ALLOY STEEL ^b	STAINLESS STEEL ^b
FF	SOUR SERVICE ^a	STAINLESS STEEL ^b	STAINLESS STEEL ^b
HH	SOUR SERVICE ^a	CRA ^{acd}	CRA ^{acd}

a) As defined by ISO 15156 (all parts) (NACE MR0175; See Clause 2).
 b) In accordance with ISO 15156 (NACE MR0175; See Clause 2).
 c) CRA required on retained-fluid wetted surfaces only.
 d) CRA as defined in Clause 3; ISO 15156 (all parts) (NACE MR0175; See Clause 2) definition of CRA does not apply.

VALVEWORKS USA DESCRIPTION KEY

GV , 6A , MOD MDS , EXP GATE , 2 1/16" 5M , FE , DD - KU - 1 - 2 , HWO

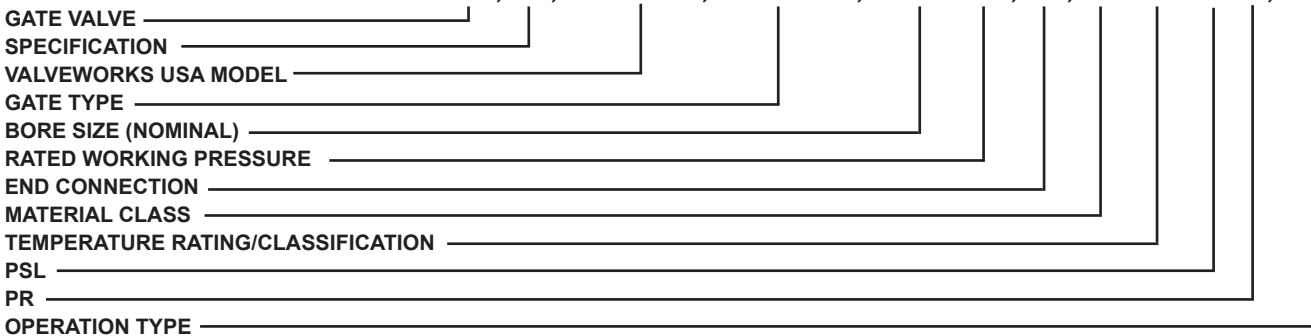

ABBREVIATION KEY

MSG = MODEL M SLAB GATE
 MDS = MODEL M DIRECTIONAL SEAL
 MRC SG = MODEL M ROUND CAVITY SLAB GATE
 MRC DS = MODEL M ROUND CAVITY DIRECTIONAL SEAL
 HWO = HANDWHEEL OPERATED (MANUAL)
 EXP = EXPANDING

SG = SLAB GATE
 FE = FLANGED END
 RTJ = RING TYPE JOINT
 PSL = PRODUCT SPECIFICATION LEVEL
 PR = PERFORMANCE REQUIREMENT
 LP = LINE PIPE

STC = CASING (SHORT THREAD)
 LC = CASING (LONG THREAD)
 EU = TUBING, EXTERNAL UPSET
 CRA = CORROSION-RESISTANT ALLOY
 XYL = XYLAN®
 HF = HARDFACED

DIMENSION TABLE KEY

- A** FACE TO FACE
- B** VALVE BORE SIZE (NOMINAL)
- C** BORE CENTERLINE TO BOTTOM
- D** BORE CENTERLINE TO TOP
- E** HANDWHEEL DIAMETER
- NT** NUMBER OF TURNS
- RJ** RING JOINT
- TS** THREAD SIZE
- BSS** BONNET STUD SIZE
- N** NUMBER OF STUDS
- WT** APPROXIMATE WEIGHT
- HT** HANDWHEEL OPERATING TORQUE

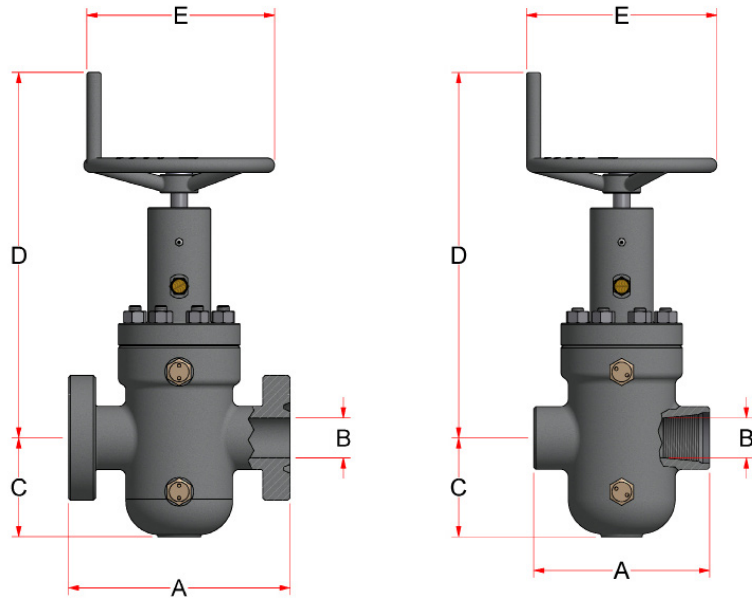

FLANGED GATE VALVES

SIZE	WP (PSI)	A	B	C	D	E	NT	RJ	BSS	N	WT (LBS)	HT (FT-LBS)
2 1/16	2K	11 5/8	2 1/16	5 1/4	19 1/2	10	14	R-23	5/8	8	120	32
	3K	14 5/8	2 1/16	5 1/2	19 5/8	13	14	R-24	7/8	8	180	40
	5K	14 5/8	2 1/16	5 1/2	19 5/8	13	14	R-24	7/8	8	180	57
2 9/16	2K	13 1/8	2 9/16	6 3/8	20 1/2	13	16 1/2	R-26	5/8	8	180	37
	3K	16 5/8	2 9/16	6 5/8	20 7/8	16	16 1/2	R-27	7/8	8	220	49
	5K	16 5/8	2 9/16	6 5/8	20 7/8	16	16 1/2	R-27	7/8	8	220	66
3 1/8	2K	14 1/8	3 1/8	7 5/8	22 7/8	13	20 3/4	R-31	7/8	8	220	48
	3K	17 1/8	3 1/8	7 5/8	23	16	20 3/4	R-31	1	8	300	65
	5K	18 5/8	3 1/8	7 5/8	23	16	20 3/4	R-35	1	8	340	90
4 1/16	2K	17 1/8	4 1/16	9 5/8	26 1/2	16	24 3/4	R-37	1	8	360	81
	3K	20 1/8	4 1/16	9 5/8	26 5/8	20	24 3/4	R-37	1 3/8	8	520	67
	5K	21 5/8	4 1/16	9 5/8	26 5/8	20	24 3/4	R-39	1 3/8	8	560	130
5 1/8	2K	22 1/2	5 1/8	11 3/4	30	24	30 1/4	R-41	1 3/8	8	770	150
	3K	24 1/8	5 1/8	11 3/4	30	24	30 1/4	R-41	1 3/8	8	810	210
	5K	28 5/8	5 1/8	11 3/4	30	24	30 1/4	R-41	1 3/8	8	940	366

THREADED GATE VALVES

SIZE	WP (PSI)	A	B	C	D	E	NT	TS	BSS	N	WT (LBS)	HT (FT-LBS)
2 1/16	5K	9 5/8	2 1/16	5 1/2	19 5/8	13	14	2 LP 2 3/8 EU	7/8	8	125	57
2 9/16	3K	10 1/4	2 9/16	6 5/8	20 7/8	16	16 1/2	2 1/2 LP	7/8	8	160	49
	5K	10 1/4	2 9/16	6 5/8	20 7/8	16	16 1/2	2 7/8 EU	7/8	8	160	66
3 1/8	3K	11 3/8	3 1/8	7 5/8	23	16	20 3/4	3 LP	1	8	230	65
	5K	11 3/8	3 1/8	7 5/8	23	16	20 3/4	3 1/2 EU	1	8	230	90
4 1/16	3K	13	4 1/16	9 5/8	26 5/8	20	24 3/4	4 LP	1 3/8	8	420	67
	5K	13	4 1/16	9 5/8	26 5/8	20	24 3/4	4 1/2 EU 4 1/2 LC	1 3/8	8	420	130

*ALL DIMENSIONS ARE IN INCHES

ENGINEERED - DESIGNED - VERIFIED - QUALITY ASSURED - CERTIFIED - FIELD PROVEN - CREDIBLE - SUPPORTED

MODEL MDS - UNIDIRECTIONAL, EXPANDING GATE, CAST BODY

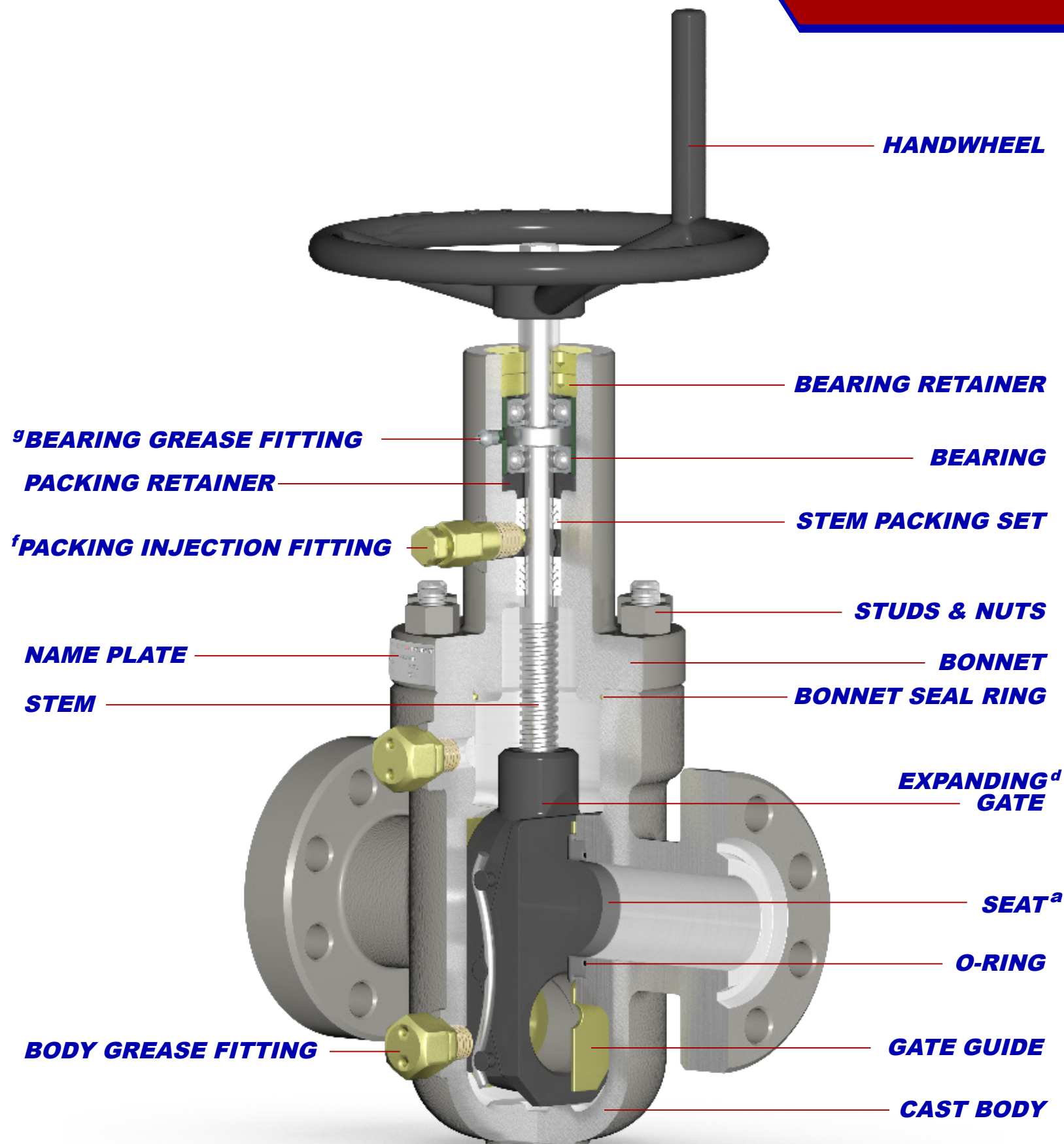

a) Equipped with a non-sealing seat on the upstream side. See engineering note titled "Model MDS (Model M Directional Seal)" for details.

d) See engineering note titled "Expanding Gate Assembly Operation Explained" for details.

f) Stuffing box can be repacked via injectable packing while the valve is in service up to the rated working pressure.

g) Valve bonnet equipped with grease port(s) and fitting(s) for bearing lubrication.

*THE ACTUAL PRODUCT MAY VARY SLIGHTLY FROM SHOWN SCHEMATIC DUE TO ENGINEERING APPROVED VARIATION

ENGINEERED - DESIGNED - VERIFIED - QUALITY ASSURED - CERTIFIED - FIELD PROVEN - CREDIBLE - SUPPORTED

MODEL MSG - BIDIRECTIONAL, SLAB GATE, CAST BODY

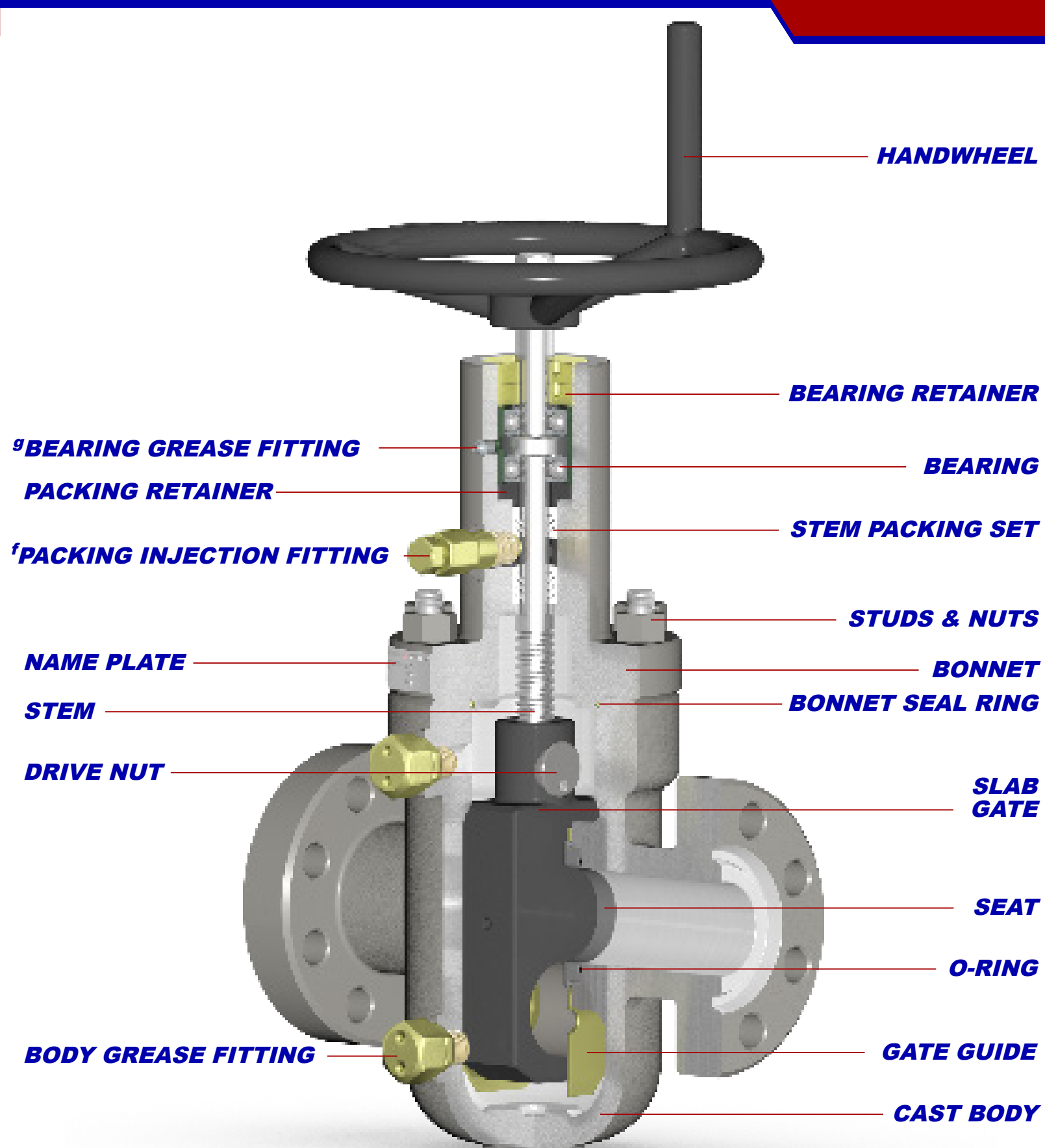

f) Stuffing box can be repacked via injectable packing while the valve is in service up to the rated working pressure.

g) Valve bonnet equipped with grease port(s) and fitting(s) for bearing lubrication.

*THE ACTUAL PRODUCT MAY VARY SLIGHTLY FROM SHOWN SCHEMATIC DUE TO ENGINEERING APPROVED VARIATION

ENGINEERED - DESIGNED - VERIFIED - QUALITY ASSURED - CERTIFIED - FIELD PROVEN - CREDIBLE - SUPPORTED

MODEL MRC DS - UNIDIRECTIONAL, EXPANDING GATE, FORGED BODY

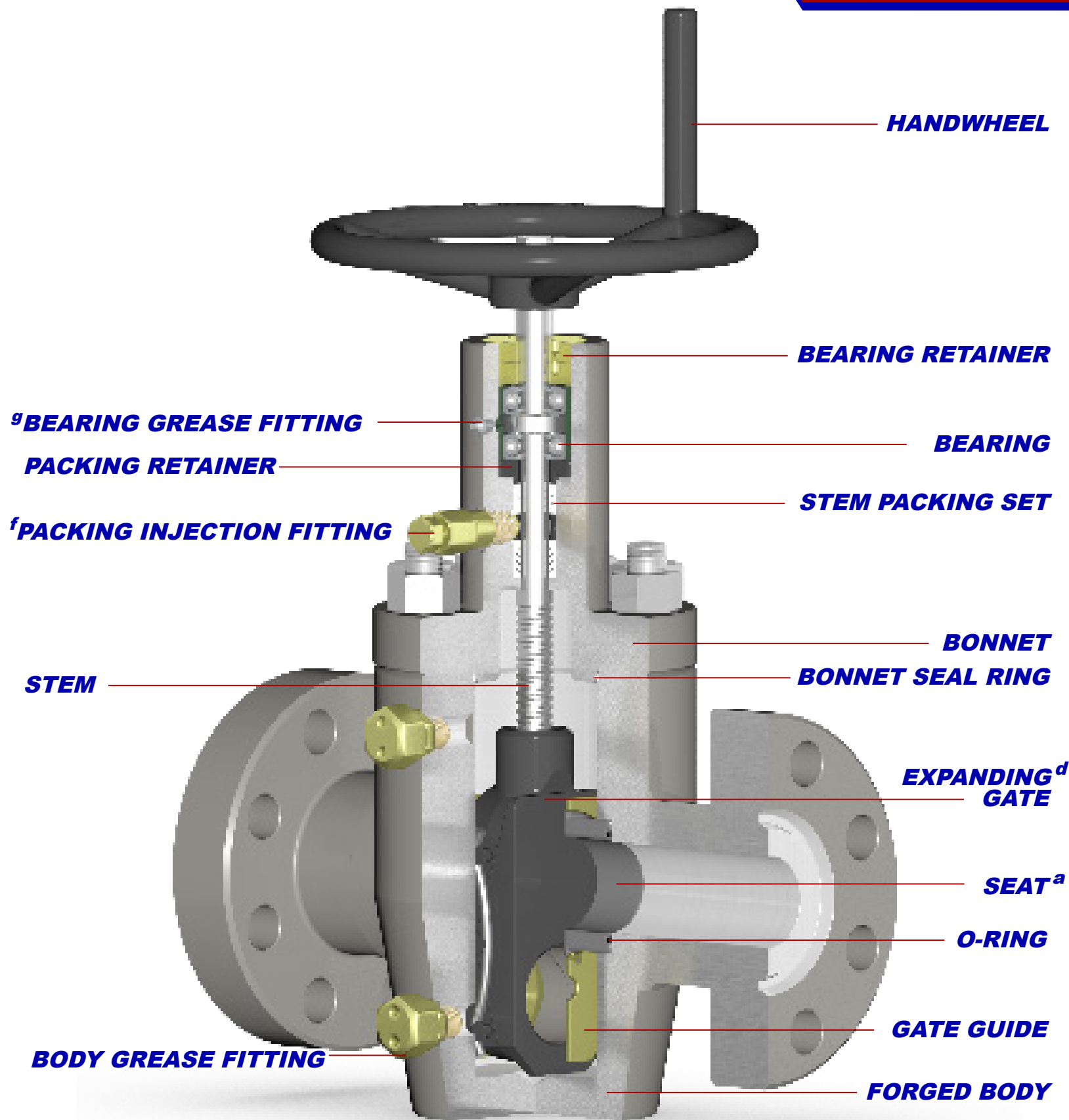

a) Equipped with a non-sealing seat on the upstream side. See engineering note titled "Model MDS (Model M Directional Seal)" for details.

d) See engineering note titled "Expanding Gate Assembly Operation Explained" for details.

f) Stuffing box can be repacked via injectable packing while the valve is in service up to the rated working pressure.

g) Valve bonnet equipped with grease port(s) and fitting(s) for bearing lubrication.

*THE ACTUAL PRODUCT MAY VARY SLIGHTLY FROM SHOWN SCHEMATIC DUE TO ENGINEERING APPROVED VARIATION

ENGINEERED - DESIGNED - VERIFIED - QUALITY ASSURED - CERTIFIED - FIELD PROVEN - CREDIBLE - SUPPORTED

MODEL MRC SG - BIDIRECTIONAL, SLAB GATE, FORGED BODY

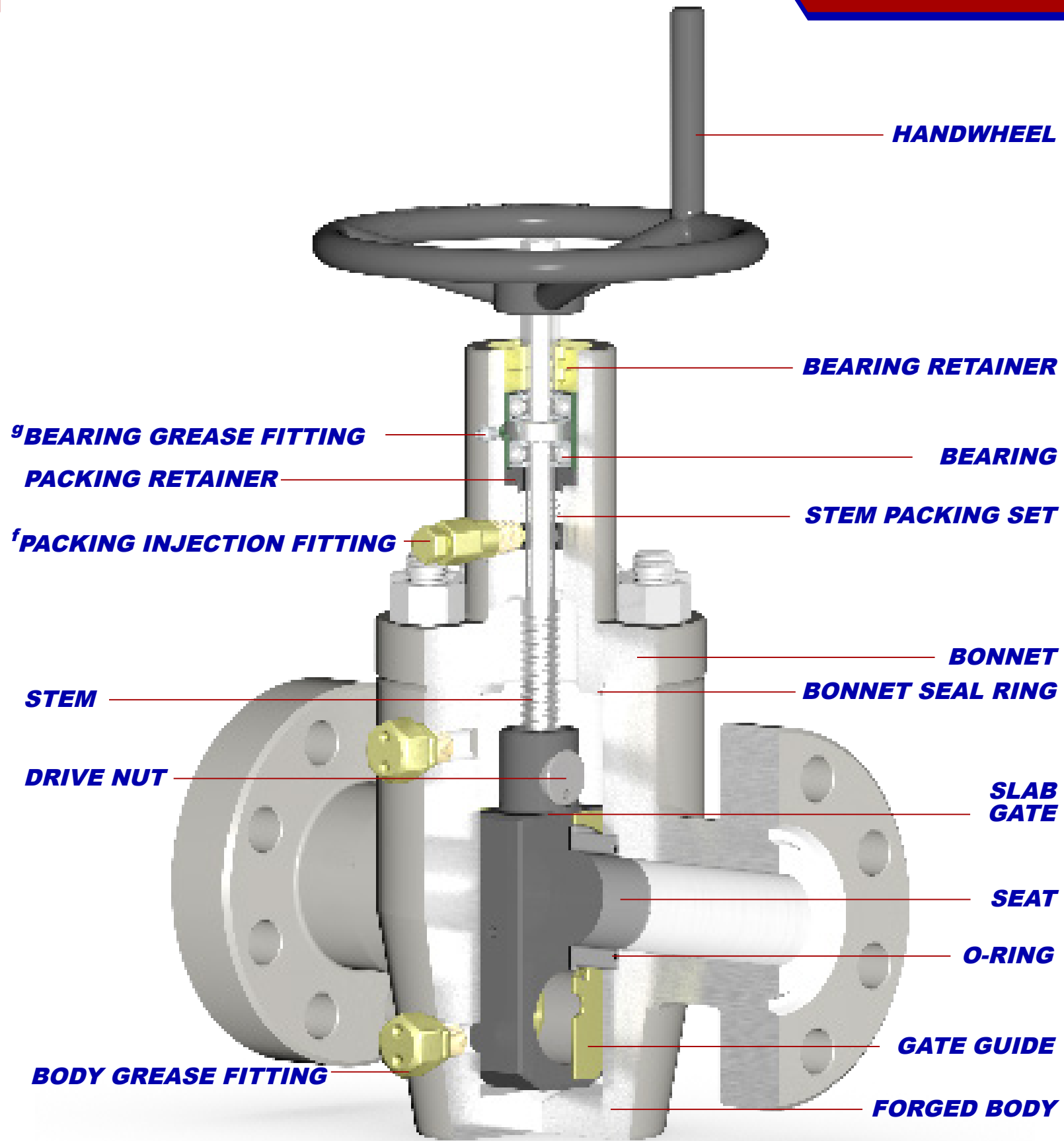

f) Stuffing box can be repacked via injectable packing while the valve is in service up to the rated working pressure.

g) Valve bonnet equipped with grease port(s) and fitting(s) for bearing lubrication.

*THE ACTUAL PRODUCT MAY VARY SLIGHTLY FROM SHOWN SCHEMATIC DUE TO ENGINEERING APPROVED VARIATION

ENGINEERED - DESIGNED - VERIFIED - QUALITY ASSURED - CERTIFIED - FIELD PROVEN - CREDIBLE - SUPPORTED